

HI HLPB SERIES LOAD POINT ASSEMBLIES

OPERATION AND INSTALLATION MANUAL

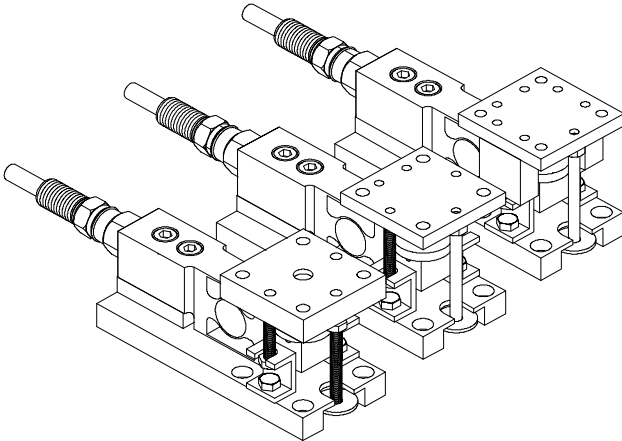

Corporate Headquarters
3860 Calle Fortunada
San Diego, CA 92123-1825
Phone: (858) 278-2900
FAX: (858) 278-6700
Web-Site: <http://www.hardyinst.com>

Hardy Instruments Document Number: 0596-0238-01 Rev C-1
Copyright November 1999 Hardy Instruments, Inc. All Rights Reserved. Printed in the U.S.A. (941028)



Local Field Service

Hardy has over 200 field technicians in the U.S., and more positioned throughout the world to assist you in your support needs. We also have factory engineers who will travel to your facility anywhere in the world to help you solve challenging applications. We're ready to support you with:

- **Installation and start-up**
- **Routine maintenance and certification**
- **Plant audits and performance measurement**
- **Emergency troubleshooting and repair**

To request Emergency Service and Troubleshooting, Start-up, Installation, Calibration, Verification or to discuss a Maintenance Agreement please call **800-821-5831 Ext. 1757** or Emergency Service after hours (Standard Hours 6:00 AM to 6:00 PM Pacific Standard Time) and weekends Ext. 1111.

Outside the U.S

Hardy Instruments has built a network of support throughout the globe. For specific field service options available in your area please contact your local sales agent or our U.S. factory at +1 **858-292-2710, Ext. 1757**.

CAUTION:

UNPACK WITH CARE

WHEN UNPACKING, DO NOT DISCARD THE PACKING CASE OR ANY PACKING MATERIAL, UNTIL THE CONTENTS OF THE PACKING CASE ARE INSPECTED AND CAREFULLY COMPARED WITH THE SHIPPING DOCUMENTS.

IF ANYTHING IS UNSATISFACTORY, PLEASE NOTIFY HARDY INSTRUMENTS IMMEDIATELY BY CALLING, FAXING OR E-MAILING TO:

Customer Support Department
HARDY INSTRUMENTS, INC.
3860 Calle Fortunada
San Diego, California 92123-1825

Phone: (800) 821-5831
(858) 278-2900

FAX: (858) 278-6700

E-mail: hardysupport@hardyinst.com
Web Address: www.hardyinst.com

A RETURN AUTHORIZATION NUMBER IS REQUIRED BEFORE RETURNING ANY DAMAGED PRODUCT. CALL THE CUSTOMER SUPPORT DEPARTMENT TO GET THE NUMBER. YOUR COMPANY NAME, ADDRESS, TELEPHONE NUMBER, SERIAL NUMBER OF THE UNIT AND A BRIEF DESCRIPTION OF THE PROBLEM SHOULD BE READY WHEN CALLING.

IN CASE OF DAMAGE DUE TO SHIPPING, NOTIFY THE DELIVERING CARRIER IMMEDIATELY FOR AN INSPECTION.

Table of Contents

General Information - - - - -Page 1
Three Load Point Types - - - - -Page 1
Unpacking - - - - -Page 3
Installation of the Ground Strap - - - - -Page 3
Site Preparation - - - - -Page 5
Precautions - - - - -Page 6
Basic Engineering Principles for
Positioning Load Point Assemblies - - - - -Page 6
 Principle #1 - - - - -Page 6
 Principle #2 - - - - -Page 6
 Principle #3 - - - - -Page 6
 Principle #4- - - - -Page 7
Typical Mounting Arrangements - - - - -Page 7
 Round Vessel with 3 Load Point Assemblies - - - - -Page 7
 Round Vessel with 3 Load Point
 Assemblies - Angle Config. #1 - - - - -Page 8
 Round Vessel with 3 Load Point
 Assemblies - Angle Config. #2 - - - - -Page 8
 Square Hopper with 3 Load Point
 Assemblies - Even Load Distribution - - - - -Page 9
 Square Hopper with 3 Load Point
 Assemblies - Uneven Load Distribution - - - - -Page 9
 Typical 4 - Load Point Assembly Installation - - - - -Page 10
 Typical 6 - Load Point Assembly Installation - - - - -Page 10
Level Requirements - - - - -Page 10
Stiffness - - - - -Page 11
Installation Procedures - - - - -Page 11
 Pre-Installation Procedures - - - - -Page 11
 Installing Load Point Assemblies with
 Anchor Bolts - - - - -Page 12
 Installing the Base Plate - - - - -Page 12
 Installing the Top Plate to the Load Surface - - - - -Page 17
Adjusting the Anti-Lift Off Device - - - - -Page 20
Replacing the Load Sensor - - - - -Page 21
Troubleshooting - - - - -Page 24
 Physical Checks - - - - -Page 24
 Electrical Tests for Load Point
 Assembly Problems - - - - -Page 25
 Zero Balance Test - - - - -Page 25
 Bridge Resistance Test - - - - -Page 25
 Resistance to Ground Test - - - - -Page 26

HI HLPB SERIES LOAD POINT ASSEMBLY

Electrical Termination Cable Color Codes - - - - -Page 26
Model Numbers - - - - -Page 27
 Three Leg Systems - - - - -Page 28
 Four Leg Systems - - - - -Page 28
Specifications - - - - -Page 28

Congratulations, on your purchase of the Hardy Instruments Load Point Assembly. This product, is engineered to set a new standard in load point assemblies. Hardy combined new innovations with previously extra cost features and just plain common sense features and provided you with optimum performance unequalled anywhere.

General Information

The Hardy Instruments HI HLPB Hermetic Load Point System is designed to provide accurate output in the most demanding applications. The load sensor performance exceeds IP68 and NEMA 6 Standards for Wash Down Resistance.

The HI HLPB Free Sliding Load Point System is designed for use on medium capacity vessels. The pre assembled Free Sliding Load Point System consists of three (3) different low profile mount types (See Figs. 1,2,3) specifically designed to eliminate the effects of unwanted forces and resulting in exceptional load measuring accuracy.

Each load point consists of a stainless steel load sensor which is truly hermetically sealed (gauge area and cable entry), Enhanced C2[®] Second Generation Calibration, matched mV/V and mV/V/Ohm and a 1/4 inch conduit adapter. The load points are pre assembled at our factory eliminating any assembly in the field. Each load point is fitted with a grounding strap and anti-lift off protection. The load points mounting hardware is available in either stainless or galvanized steel.

Three Load Point Types

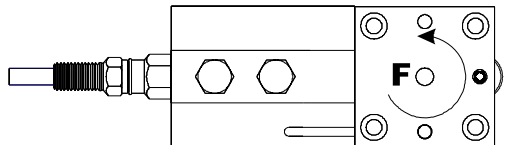

HI HLPB SERIES LOAD POINT ASSEMBLY

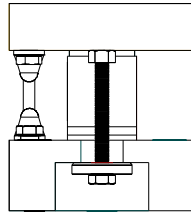

FIG. 1: FIXED PIN LOAD POINT

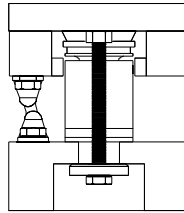
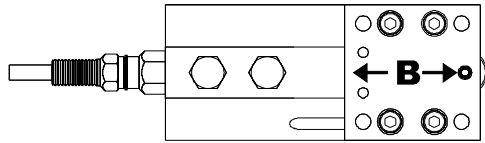
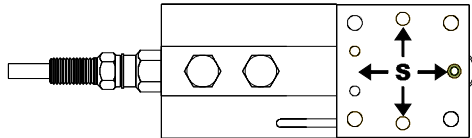

FIG. 2: BUMPER PIN LOAD POINT



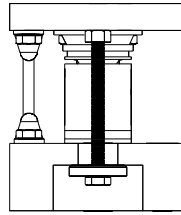

FIG. 3: FREE SLIDING PIN LOAD POINT

Unpacking

- Do not remove the load point assembly from its packaging until just before installation. Although the load sensor is designed for harsh environments, it is a precision instrument and should be treated as such.
- Inspect the box, packing and the load point assembly for any signs of damage that might occur during shipment. Since almost all of the load point assemblies are shipped F.O.B. our factory, such damage is normally the responsibility of the carrier and should be reported to them.
- **LOAD SENSOR CERTIFICATION SHEETS ARE AVAILABLE 24 HOURS A DAY AT OUR WEBSITE: <http://www.hardinst.com>**
- Write down the serial number(s) on the inside of the back cover for reference when talking to Hardy Customer Service. Store this information in a secure dry location for future reference.

Installation of the Ground Strap

- Step 1. Cut the plastic strap that fastens the ground strap to the Load Point Assembly.
- Step 2. Use a box end wrench to remove the fasteners that fasten the two shipping brackets to the load point. (See Fig. 4)

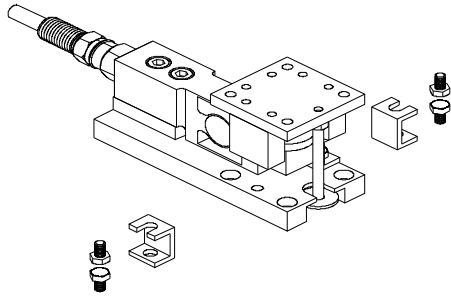

FIG. 4: REMOVING SHIPPING BRACKETS

- Step 3. Remove the shipping brackets. Place them in a secure location, so you can reinstall the shipping brackets in the event you need to ship the load point assembly to another location.

NOTE:

Always reinstall the shipping brackets when shipping or transporting a load point assembly.

- Step 4. Save the two shortest machine screws, the ones that fasten the shipping brackets to the base plate. You will use these hex bolts to install the ground strap. (See Fig. 1-4)
- Step 5. Place one of the ground strap connectors over the threaded hole in the base plate. These are the ones that fastened the shipping bracket to the base. (See Fig. 5)

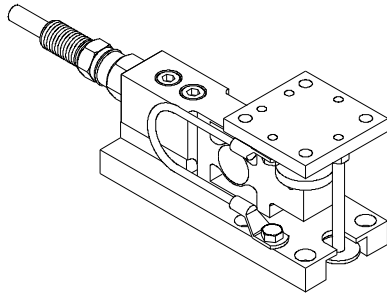

FIG. 5: GROUND STRAP INSTALLED

- Step 6. Install the hex bolt. Tighten with a box end wrench.
- Step 7. Place the other ground strap connector over the threaded hole in the top plate.
- Step 8. Install the other hex bolt. Tighten with a box end wrench.
- Step 9. In the illustration we show the ground strap installed on the left side when facing the front of the load point assembly. However, you can install the strap on either side if necessary.

NOTE:

Do not connect the ground strap to the base plate on the right side and to the top plate on the left side or vice versa. Crossing over will interfere with the load cell performance.

Site Preparation

- All mounting surfaces for the base and loading plate must be level. The distance between the mounting surface of the loading plate and base must within 1/32" of the nominal height, "H". The Load Point Assemblies in a system must be level to within +/- 0.5°.
- When mounting the base plate on concrete, use grout to level the plate.
- Any welding should be done prior to installation of the load points.
- Proper drainage must be provided to prevent the load point assembly from standing in water.

HI HLPB SERIES LOAD POINT ASSEMBLY

Precautions

- Always treat the Load Sensor as a precision instrument. Leave the load point assembly in its packaging until it is time for installation.
- NEVER CARRY OR SWING THE LOAD SENSORS BY THEIR CABLE.
- Never allow moisture to get into any interconnections.

Basic Engineering Principles for Positioning Load Point Assemblies

Principle #1

- Load Points Assemblies should be positioned such that the load (weight) is distributed as evenly as possible between each load point assembly in the scale.
- When the installation does not allow even distribution of the load, select higher capacity load point assemblies. This does not effect the weighing accuracy of the scale.

NOTE:

All load point assemblies must have the same capacity when used in one scale.

Principle #2

- All scales must include one (1) fixed pin load mount, one (1) bumper pin load mount. All other load point assemblies in a scale must be the free sliding mount.

Principle #3

- Place the fixed pin load mount and the bumper pin load mount as far as possible from each other.
- The fixed pin load mount and the bumper pin load mount must be mounted in the same longitudinal axis.
- In applications that use three load points it is sometimes difficult to mount the fixed pin and bumper load mounts in-line. Therefore the fixed pin and bumper load mounts can be positioned at a 45° angle from each other and 45° from the free pin load mount. Please see the mounting diagrams below for more information.

Principle #4

- If possible the fixed pin load mount should be installed such that the load mount is oriented in the direction of travel (e.g. when under a conveyor, the load mount must be in the same longitudinal axis with the direction of the travel of the conveyor). The load mount must be oriented in the direction of any prevalent side force.

Typical Mounting Arrangements

**Round Vessel with
3 Load Point
Assemblies**

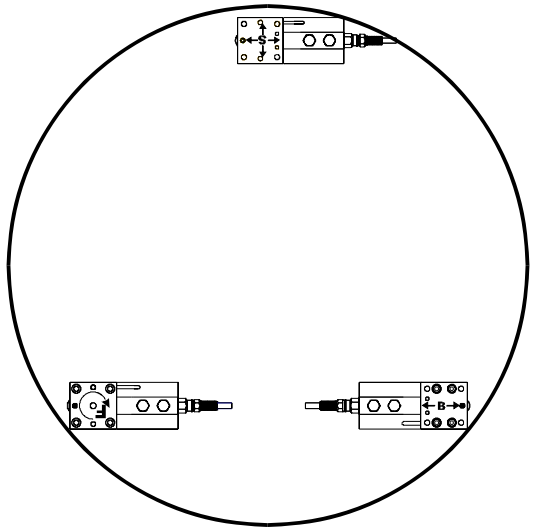

HI HLPB SERIES LOAD POINT ASSEMBLY

**Round Vessel with
3 Load Point
Assemblies -
Angle Config. #1**

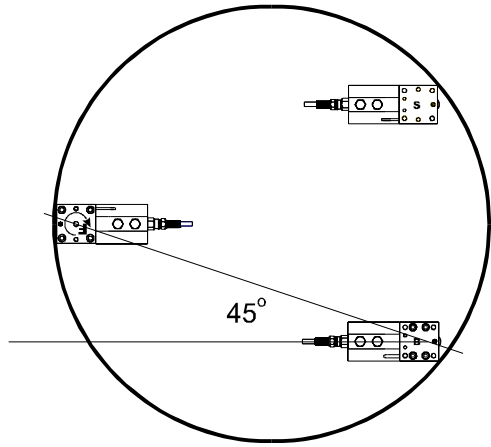

**Round Vessel with
3 Load Point
Assemblies -
Angle Config. #2**

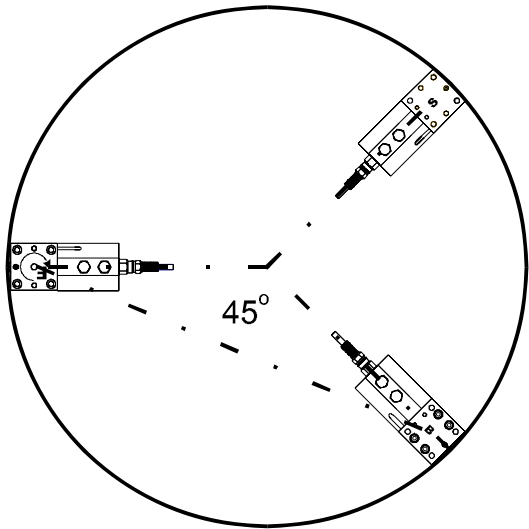

**Square Hopper
with 3 Load Point
Assemblies - Even
Load Distribution**

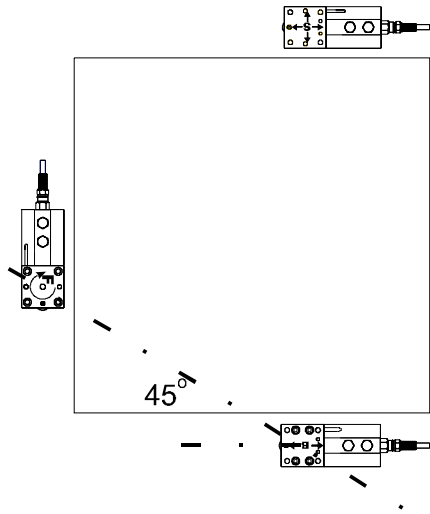

**Square Hopper
with 3 Load Point
Assemblies -
Uneven Load
Distribution**

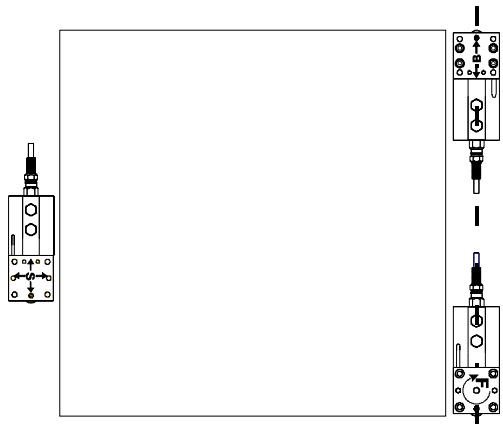

NOTE:

This configuration is an exception to the even load distribution principle. Use this configuration in circumstances where you have several hoppers arranged in close proximity to each other.

HI HLPB SERIES LOAD POINT ASSEMBLY

Typical 4 - Load Point Assembly Installation

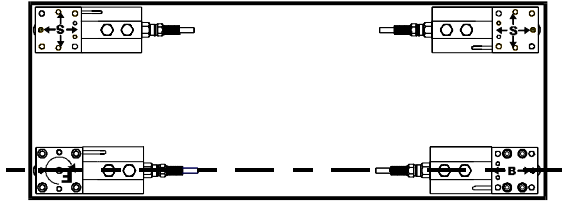

Typical 6 - Load Point Assembly Installation

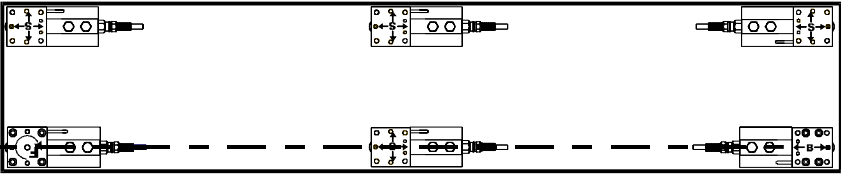

NOTE:

In case there is some doubt concerning load point assembly installation, contact your local Hardy Instruments Dealer, or Hardy Instruments, Application Engineering Department or Customer Support Department for assistance.

NOTE:

You can orient the load point assemblies to meet your system installation requirements. All load point assemblies can be rotated 360° in 90° increments. The examples above are recommendations only.

Level Requirements

- For scales that must meet NIST Class 3 (OIML Class 3) specifications:
 1. The base plate support surfaces must be within 0.2 degrees (0.4mm/100mm)
 2. The top plate support surfaces in the load carrier must be within 0.5 degrees (0.9mm/100mm)

- For scales with accuracy requirements => 0.1%
 1. The base plate support surfaces must be within 0.4 degrees (0.08mm/100mm)
 2. Top plate support surfaces in the load carrier must be within 1 degree (1.8mm/100mm)

Stiffness

Load variations and external forces can cause support surface level variations.

- For scales that must meet NIST Class 3 (OIML Class 3) specifications:
 1. Maximum base plate angle variation: 0.2 degrees.
 2. Maximum top plate angle variation 0.5 degrees.
- For scales that must meet accuracy specifications => 0.1%
 1. Maximum base plate angle variation 0.2 degrees
 2. Maximum top plate angle variation 1 degree.

Installation Procedures

Pre-Installation Procedures

- Step 1. Position the base plates with load cells on the support surfaces and line them up in accordance with the basic principles for positioning. (See Principle #2, pg. 7)
- Step 2. We recommend scribing or marking a centerline on the top plate. (See Fig. 6)

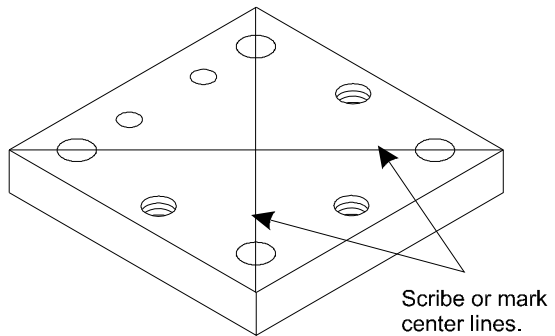

FIG. 6: MARKING TOP PLATE FOR INSTALLATION

Installing Load Point Assemblies with Anchor Bolts

Check the I/I diagrams located on the www.hardy-inst.com site. The diagrams will give you the Base Plate and Top Plate dimensions for the Load Point Assembly you are installing, including the thru hole diameters and center distances. If you do not have Internet access, contact your local Hardy Dealer for a copy of the I/I diagram.

Installing the Base Plate

- Step 1. Make sure that the concrete foundation is level.
- Step 2. To assist in the installation of the anchor bolts we recommend creating a template using the thru hole diameters of the base plate and the center distances that appear on the base and top plate mounting dimensions. (See Figs. 7 & 8)

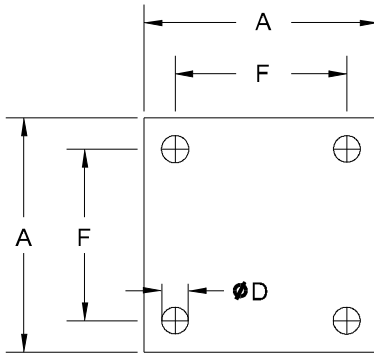

FIG. 7: BASE AND TOP PLATE DIMENSIONS

CAPACITY LBS (kN)	A	F	DIA. D
44 (0.2)	2.36" (60)	1.73" (44)	.275" (7)
50 (.5)			
100 (1)			
200 (2)			

TABLE 1: BASE AND TOP PLATE DIMENSIONS

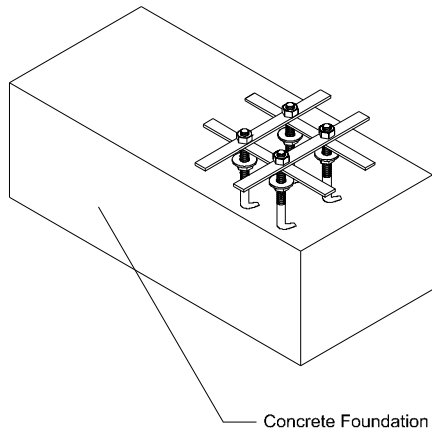

FIG. 8: ANCHOR BOLTS TEMPLATE

- Step 3. Use wood or metal to create the templates. The size of the template depends on the size of the anchor bolts.
- Step 4. Mark a point on the template. Use the thru hole center distances from the I/I diagram and measure to another point on the template which equals the center distance of the thru holes on the base plate and make another mark. Do this for each template.
- Step 5. Drill the thru holes the same size as the base plate thru holes at each of the marks you made on the templates.
- Step 6. On the Vessel or structural support that will rest on the load point assemblies, measure from where you want the center of the fixed pin load point assembly's top plate to be located, to the centers of where you want the centers of the top plates of the other load point assemblies used in the weighing system. Mark each center point location. Please check the typical mounting arrangements for load point systems above.
- Step 7. Place the center of the Anchor Bolt pattern at the exact centers as measured in Step 6.

OPERATION AND INSTALLATION MANUAL

You can use the templates to assist in locating these center points.

- Step 8. When you place the Anchor Bolts into the concrete foundation, slip the templates over the anchor bolts so that the bolt center distances will be the same as the base plate thru holes of the load cell. You can leave the templates on until after the concrete dries or remove them when you think the concrete has set to the point where the anchor bolts won't move.
- Step 9. Make sure to leave room to install the jacking nuts and washers. You are going to make the level adjustments with the jacking nuts. (See Fig. 9)

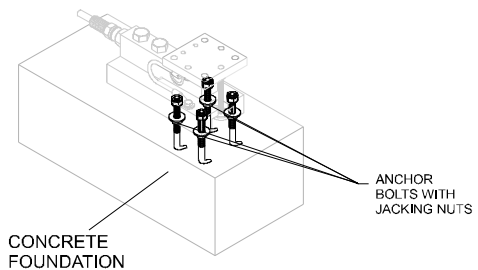

FIG. 9: INSTALLING THE FOUR ANCHOR BOLTS FOR THE BASE PLATE

- Step 10. Install the correct size Jacking Nuts onto the Anchor Bolts so there is about 1/2 inch between the concrete foundation and the jacking nuts. Don't worry about level at this point, you will level everything after the Load Point Assembly/base plate is Installed.
- Step 11. Install four (4) flat washers on each anchor bolt above the jacking nuts. (See Fig. 9)
- Step 12. Slide the load point assembly/base plate onto the anchor bolts. You can install the load point assemblies in one of four orientations. (See Fig. 10) Notice we used the Free Sliding Load Point Assembly for this

illustration but you can do the same with any of the load point assembly types.

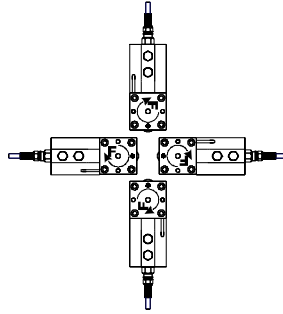

FIG. 10: LOAD POINT ASSEMBLIES ORIENTATION

- Step 13. Use a small spirit (bubble) level and check to see if the load point assembly is level side to side/corner to corner. Use a box end wrench to adjust each of the jacking nuts until each load point assembly in the system is level.
- Step 14. Install the base plate nuts. (See Fig. 9) Tighten them finger tight. You may need to adjust the jacking nuts later as you install the rest of the load point assemblies for the weighing system.
- Step 15. If you replaced a loading pin or load cell, make sure you:
- Grease the sliding pin. Grease the fixed pin and the fixed pin housings in the top plate and the load cell.
 - Wipe the stainless plate on the under side of the top plate clean and check to see that the stainless plate is free of scratches or other damage. Replace the Stainless plate if scratched or damaged.

- Step 16. Install the rest of the load point assemblies according to the Positioning Principles. (See Principle #2, pg. 7)

NOTE:

Load variations and external forces can cause support surface level variations.

- Step 17. Check all the installed load point assemblies for level and make adjustments according to the following base plate level requirements:

- For scales with accuracy according to NIST (OIML) Class 3:
 1. Base plate support surfaces should be within 0.2 degrees (0.4mm/100mm).
 2. Maximum loadcell base plate angle variation 0.2 degrees.
- For scales with accuracy requirements => 0.1%:
 1. Base plate support surfaces should be within 0.4 degrees. (0.08mm/100mm)
 2. Maximum loadcell base plate angle variation 0.2 degrees.

Installing the Top Plate to the Load Surface

- Step 1. You should have scribed or marked a centerline on the top surface of the top plate to locate the center. (See Fig. 6)

- Step 2. Mark the point you want the center of the top plate to be located on the support bracket. Place the top plate center over the support bracket mark and:

- Tack Weld the top plate to the support bracket.
- If you want to use fasteners to fasten the top plate to the support bracket, use a marker or

HI HLPB SERIES LOAD POINT ASSEMBLY

scribe and trace the thru hole pattern of the top plate on the support bracket. Drill four (4) thru holes or drill and tap four (4) holes for the fasteners.

Install the top plate to the support bracket using the four (4) fasteners.

Step 3. With the top plates installed, put the vessel support bracket with the top plate onto the pins of the load cells. Make sure that the sliding load cell pins are riding on the stainless plate. Make sure that the fixed pin is centered in the top plate housing. The horizontal position is not critical but the vertical position is. Use the C dimensions to determine the proper height between the support surface and the top of the top plate. (See Fig. 11)

Step 4. Check all the installed load point assemblies for level and make adjustments according to the following top plate level requirements:

- For scales with accuracy according to NIST (OIML) Class 3:
 1. Top plate support surfaces in the load carrier should be within 0.5 degrees (0.9mm/100mm).
 2. Maximum top plate angle variation 0.5 degrees.
- For scales with accuracy requirements => 0.1%:
 1. Top plate support surfaces in the load carrier should be within 1 degree (1.8mm/100mm).

OPERATION AND INSTALLATION MANUAL

- Maximum top plate angle variation 1 degree.

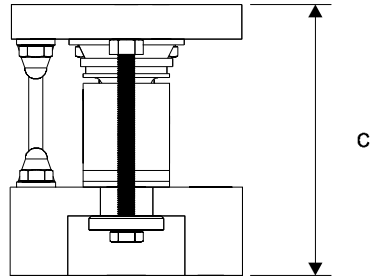

FIG. 11: HEIGHT DIMENSION C

MODEL #	HEIGHT C
HI HLPB44-43	3.149" (80)
HI HLPB110-43	
HI HLPB225-43	
HI HLPB450-43	

TABLE 2:

- Step 5. To adjust the level of the top plate use shim stock between the top plate and the support bracket. (See Fig. 12)

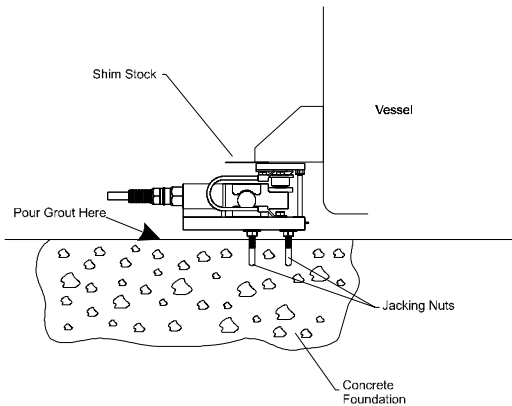

FIG. 12: ADJUSTING FOR LEVEL WITH SHIM STOCK

- Step 6. If you tack welded the top plate to the support bracket, if you can, lift the vessel off the load cell pins and finish welding the top plate to the support bracket. If you cannot be sure to shield the entire load cell and cable from any slag that might drop. Lower the vessel back onto the sliding loading pins.

WARNING

UNDER NO CIRCUMSTANCES MUST WELDING CURRENT BE ALLOWED TO PASS THROUGH THE LOAD SENSOR. TO DO SO WILL DESTROY THE LOAD SENSOR AND COULD POSSIBLY CAUSE PERSONAL INJURY AND/OR PROPERTY DAMAGE.

- Step 7. Pour grout up to the bottom surface of the base plate and let dry.

Adjusting the Anti-Lift Off Device

- Step 1. Use a box end wrench to loosen the adjustment hex nut that fastens the Anti-Lift Off Device to the top plate. (See Fig. 13)

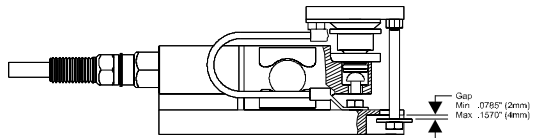

FIG. 13: ANTI-LIFT OFF DEVICE ADJUSTMENT

- Step 2. Use a box end wrench or your fingers to adjust the hex screw until the gap between the base plate and the washer are between .0785" (2mm) and .1570" (4mm). (See Fig. 13)
- Step 3. Use a box end wrench and tighten the adjustment hex nut.

Replacing the Load Sensor

- Step 1. Use a box end wrench to loosen the nut that fastens the Anti-Lift Off Device to the top plate. Remove the Anti-Lift Off Device. (See Fig. 14)
- Step 2. Use a box end wrench to remove the two hex bolts that fasten the ground strap to the top plate and the base plate. Remove the ground strap.
- Step 3. Jack up the vessel support leg and lift off the top plate.
- Step 4. Use a box end or crescent wrench to remove the two (2) load sensor bolts that fasten the Load Sensor to the base plate. (See Fig. 14)

HI HLPB SERIES LOAD POINT ASSEMBLY

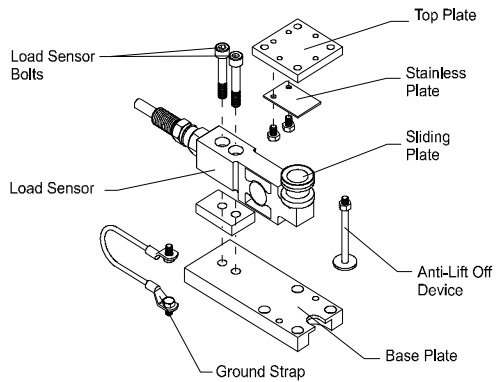

FIG. 14: EXPLODED ISO VIEW OF FREE SLIDING LOAD POINT ASSEMBLY

- Step 5. Remove the old load sensor.
- Step 6. Check the new load cell to see that the Sliding Plate or the Fixed Pin have grease. If they do not then grease them.
- Step 7. Align the Load Cell bolt thru holes with the threaded base plate bolt holes.
- Step 8. Screw the two (2) Load Cell Bolts into the base plate until they are finger tight only.
- Step 9. Check the height (B) dimension as measured between the bottom of the base plate and the top of the load sensor, before tightening the Load Cell Bolts with a torque wrench. (See Fig. 14 & Table 3)

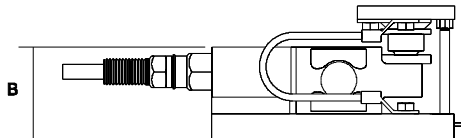

FIG. 15: B DIMENSION

MODEL #	HEIGHT B
HI HLPB44-43	2.36" (60)
HI HLPB110-43	
HI HLPB225-43	
HI HLPB450-43	

TABLE 3: B DIMENSIONS

Step 10. Use a torque wrench and tighten the bolt farthest from the cable end first. Then tighten the bolt nearest the cable end. Again refer to the B dimensions. Use the following torque values:

MODEL #	FOOT POUNDS
HI HLPB44-43B HI HLPB44-43F HI HLPB44-43S HI HLPB110-43B HI HLPB110-43F HI HLPB110-43S HI HLPB225-43B HI HLPB225-43F HI HLPB225-43S HI HLPB450-43B HI HLPB450-43F HI HLPB450-43S	18.44 (25Nm)

TABLE 4: LOAD CELL BOLT TORQUE VALUES

Step 11. Inspect the Stainless Plate for scratches or damage. If there are scratches or damage:

- Use a box end wrench and remove the two (2) hex machine screws that fasten the stainless plate to the top plate. (See Fig. 14)

HI HLPB SERIES LOAD POINT ASSEMBLY

- Discard the old stainless plate.
- Place the stainless plate so that the thru holes are aligned with the threaded holes in the top plate.
- Use a box end wrench and replace the two (2) hex machine screws.
- Lower the vessel down onto the load points.
- Reinstall the ground strap and anti-lift off device. (See Figs. 11 & 13)

Troubleshooting

Physical Checks

Before doing any electrical tests do the following:

- Step 1. Visually inspect each load point assembly for physical damage. Look for distortions or cracks in all metal parts.
- Step 2. Check all welds to be sure they are not cracked or have deep pot marks.
- Step 3. Check all cables for cracks, cuts or crimping. Check for any abrasions on the cables.
- Step 4. Look for structural changes in the scale or supporting structures.
- Step 5. Look for binding of any kind on the load point assembly.
- Step 6. In the Hardy HI 2151/30WC Manual, go to Chapter 8, Page 8-2 for information on how to troubleshoot using Integrated Technician. For your convenience this manual is available on the Hardy Web site at: <http://www.hardyinst.com> on the support page. If you do not have access to the internet, contact your local Hardy Representative for information as to where to get this and other manuals for Hardy products.
- Step 7. Get the Load Sensor certification sheets for referencing while troubleshooting. The certifications are available to you 24 hours a day at our Web Site: <http://www.hardyinst.com>

If you find any of the problems stated above, replace the part that is damaged.

**Electrical Tests for
Load Point
Assembly
Problems**

**Zero Balance
Test**

Problem: Changes in the Zero Balance.

Cause: Load Cell has been overloaded.

Remedy:

- Step 1. Use a millivolt meter or Integrated Technician feature of the HI 2151/30WC (See Physical Checks, Step 6) and measure the LPS output under “no load” conditions. The reading should be less than 1% of the full scale output.

NOTE:

Sensors can shift up to about 10% of their full scale and still function correctly.

- Step 2. If the output has shifted more than 10%, replace the sensor.

Assumption: A 5VDC excitation on a sensor with a 3mV/V output sensitivity, a 1% shift in zero balance will yield a .1mV/V change from the specification.

**Bridge
Resistance
Test**

Problem: Changes in Bridge Resistance

Cause: Failure of a compensating element, or by a broken or burned bridge wire. Often cause by an electrical transient such as lightning.

Remedy:

- Step 1. Use an Ohmmeter and measure the resistance between the EXC + and EXC- leads.
- The value for the EXC leads should be 1106 ohms + - 5 ohms.
- Step 2. Use an Ohmmeter and measure the resistance between the SIG + and SIG - leads.

HI HLPB SERIES LOAD POINT ASSEMBLY

- The value for the SIG leads should be 1,000 ohms + - 1 ohm.

Step 3. Readings that exceed the ranges indicated suggest damage and the load cell should be thoroughly inspected or replaced.

Resistance to Ground Test

Problem:Electrical leakage is creating an unstable output from the instrument.

Cause: Water contamination in the load sensors or cables.

Remedy:

Step 1. Tie together the load sensor excitation (2), signal (2) and ground (1) wires.

NOTE:

Be careful NOT to include the two C2 wires.

Step 2. Use a megohmmeter and measure the resistance between all five wires tied together and the load cell metal body.

- The measured value should be 5,000 megohms or more.

WARNING

WHEN USING A MEGGER DO NOT EXCEED 50 VOLT RANGE.

- If the sensor fails this test remove the ground wire and test with only the four live leads.
- If the sensor passes the test an insulation problem in the cable is most likely.

Step 3. Replace the load cell if the cell fails both tests.

Electrical Termination Cable Color Codes

The cable is 6 conductor, shielded (floating) and 20 feet in length.

OPERATION AND INSTALLATION MANUAL

EXC+	Red
EXC -	Black
SHIELD	Yellow
C2+	Gray
C2-	Violet
SIG +	Green
SIG -	White

Model Numbers

NOTE:

The -43E/B/S indicates a stainless steel load sensor with stainless steel mounting hardware. For galvanized mounting hardware use -45 F/B/S

Capacity		Model #	Model #	Model #
LBS	Kn	Fixed Assembly	Bumper Assembly	Slider Assembly
44	0.2	HI HLPB44-43F	HI HLPB44-43B	HI HLPB44-43S
110	0.5	HI HLPB110-43B	HI HLPB110-43B	HI HLPB110-43S
225	1	HI HLPB225-43F	HI HLPB225-43B	HI HLPB225-43S
450	2	HI HLPB450-43F	HI HLPB450-43B	HI HLPB450-43S

TABLE 5: MODEL NUMBERS & CAPACITIES

Model #
Spare Load Sensor
HI BBH06-44
HI BBH06-110
HI BBH06-225
HI BBH06-450

TABLE 6: SPARE LOAD SENSORS

HI HLPB SERIES LOAD POINT ASSEMBLY

Three Leg Systems

Total Capacity		
Model #	Pounds	Kgs
HI 3B132-43	132	60
HI 3BB330-43	330	150
HI 3B675-43	675	306
HI 3B1.35K-43	1.35 K	612

TABLE 7: THREE LEG SYSTEMS

Four Leg Systems

Total Capacity		
Model #	Pounds	Kgs
HI 4B175.5K-43	175	79
HI 4B440-43	440	200
HI 4B880-43	990	408
HI 4B1.8K-43	1.8K	816

TABLE 8: FOUR LEG SYSTEMS

Specifications

Operating Specifications

Rated Output (F.S.)	-----	2+-0.002mV
Non-Linearity	-----	+0.018% R.O.
Hysteresis	-----	<-0.025% R.O.
Zero Balance	-----	<+-1.0% R.O.
Creep @ 5 Min.	-----	<+-0.01% R.O.
Temp Effect Output	-----	<+-0.0014% R.O./C
Temp Effect Sensitivity	-----	<+-0.0007% R.O./C

OPERATION AND INSTALLATION MANUAL

Input Resistance - - - - -	1050 to 1200 ohms
Output Resistance - - - - -	1000 +- 1 ohm
Insulation Resistance - - - - -	>5000 megohms
Excitation - - - - -	5-15VDC
Safe Load Limit - - - - -	200% Emax
Ultimate Load - - - - -	300% Emax
Safe Side Load - - - - -	100% Emax

Environmental Specifications

Operating Temperature - - - - -	Minus 40° F to Plus 176° F (-40° C to +80° C)
Compensated Temperature - - - - -	14° F to 104° F (Minus 10° C to Plus 40° C)
Load Sensor Material - - - - -	17-4PH Martensitic (Magnetic) Stainless Steel
Load Sensor Fittings - - - - -	Coated Tool Steel
Top Plate & Base Plate Material - - -	316 Stainless Steel or Galvanized Steel
Conduit Adapter - - - - -	.250-18 NPT
Hermetic Sealing	
Gauging Area - - - - -	Welded Cylindrical Sleeve
Cable Entry - - - - -	Glass to Metal Header

HI HLPB SERIES LOAD POINT ASSEMBLY

Please print the unit serial number and model number for reference when ordering parts for the HI HLPB Load Point Assembly

The serial number can be found on the side of the load sensor, or by entering the SelfTest Mode of the HI 2151/30WC.

Scale Name/Location:

Model Number:

Serial Number 1:

Serial Number 2:

Serial Number 3:

Serial Number 4:

Serial Number 5:

Serial Number 6: